

100% MADE IN ITALY

ISTRUZIONI DI MONTAGGIO
ASSEMBLY INSTRUCTIONS

HOME SOFT HOME

PLATZ
BED

ISM_52LT0623

désirée 

désirée spa
Via Piave, 25,
31028 Tezze di Piave - TV - Italy
Tel. +39 04382817
info@desiree.com
desiree.com

désirée 

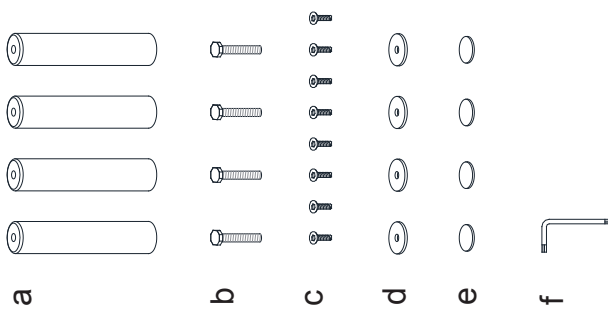
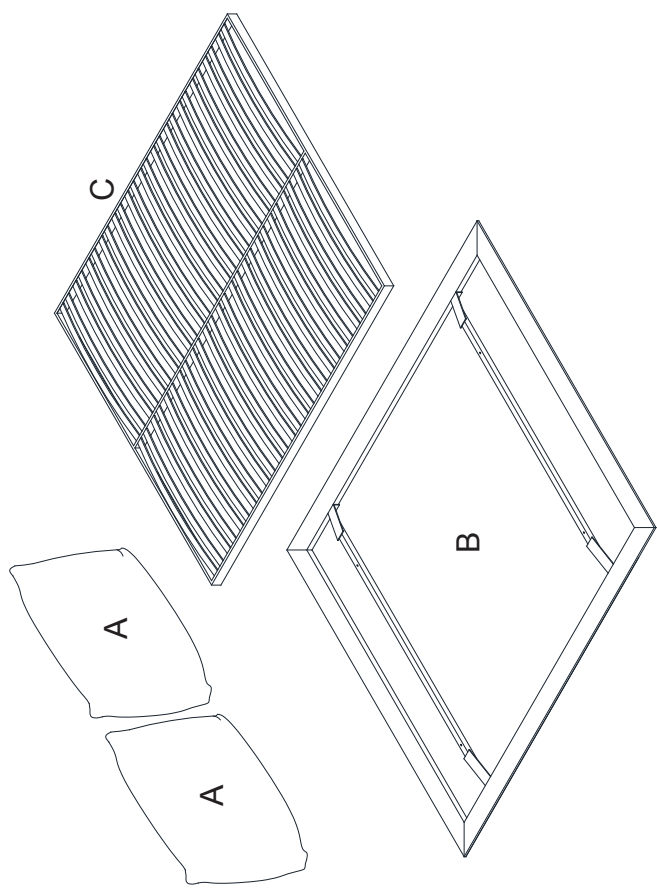

CONTENUTO

- A. n°2 testiere rivestite
 - B. n°1 struttura alluminio
 - C. n°1 rete in metallo ortopedica
- a. n°4 piedi alluminio H.180
 - b. n°4 viti 10Ma L.50 mm.
 - c. n°8 viti 6Ma L.10 mm.
 - d. n°4 rondelle
 - e. n°4 gommini
 - f. n°1 chiave per brugola (forma ad L)

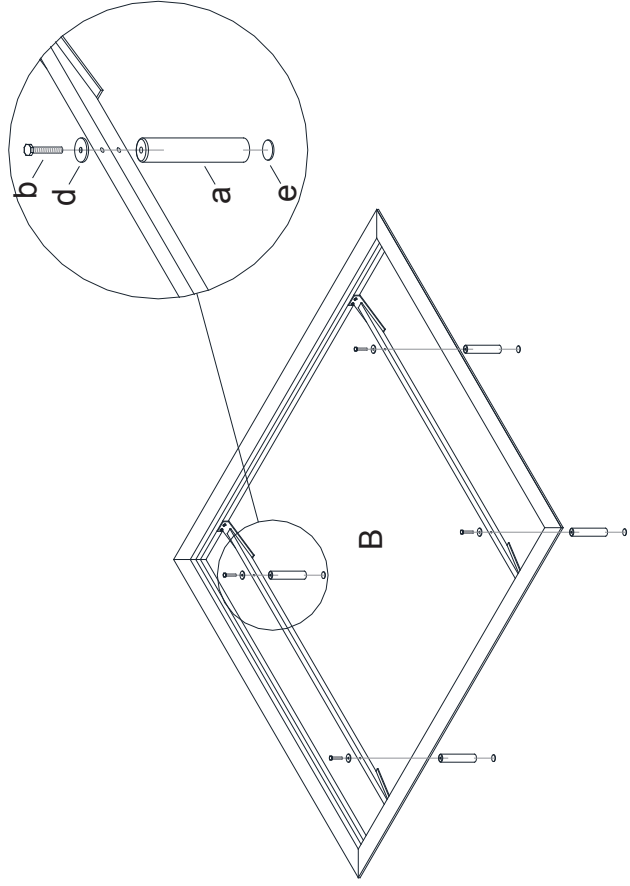

1. Avvitare i piedini sui traversi in metallo, mediante le viti 10Ma L.50 e le rondelle per poi applicare, sotto gli stessi, i gommini.

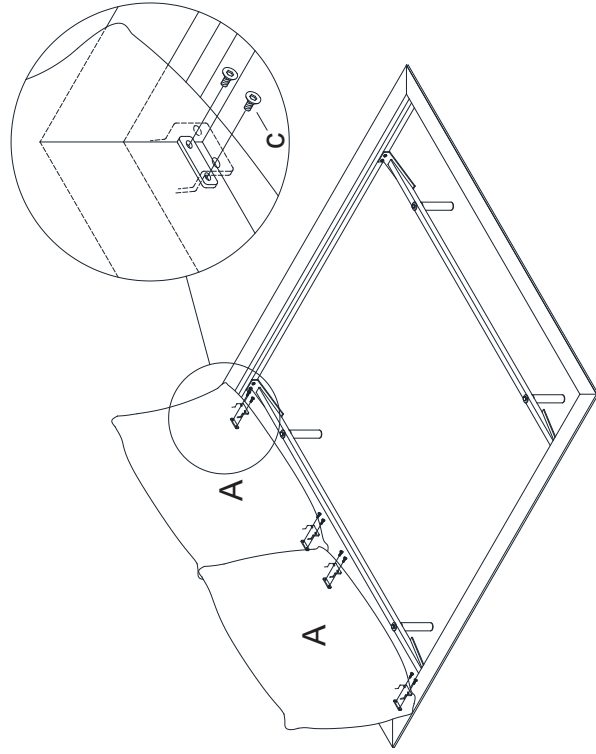

2. Fissare la testiera rivestita ai giroletti laterali mediante le viti 6Ma L.10 mm., posizionando la staffe più estreme delle testiere in prossimità dell'angolo della struttura in alluminio.

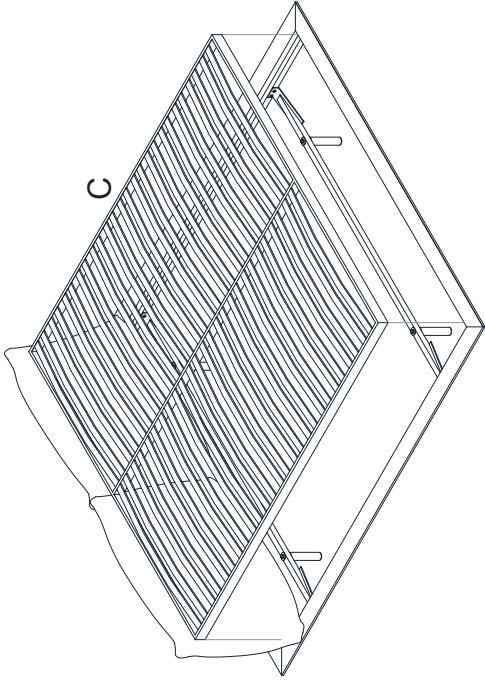

3. Place the slatted base inside the bed surround.

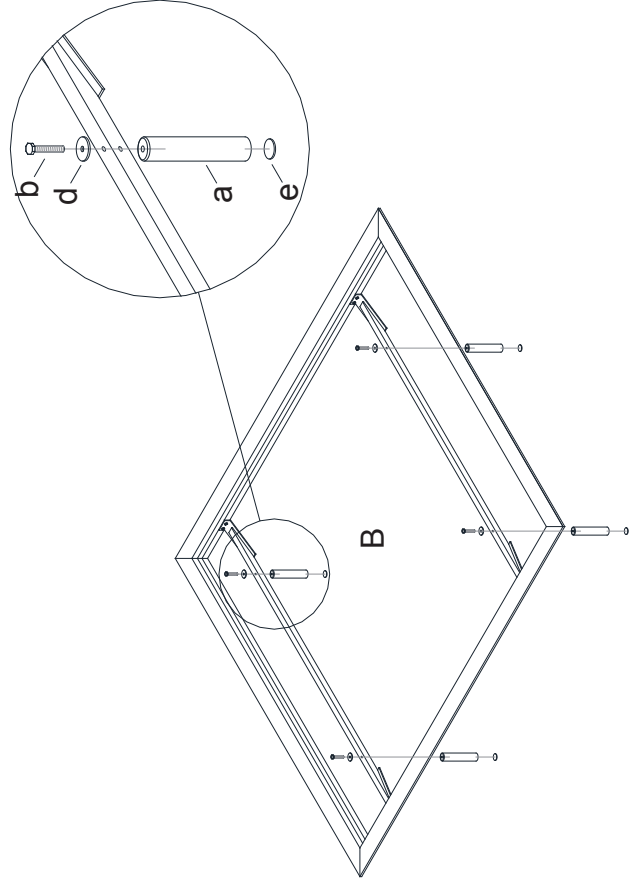

1. Screw the feet into the metal crossbars using the 10Ma screws L.50 mm. and the washers and then apply under them, the rubber caps.

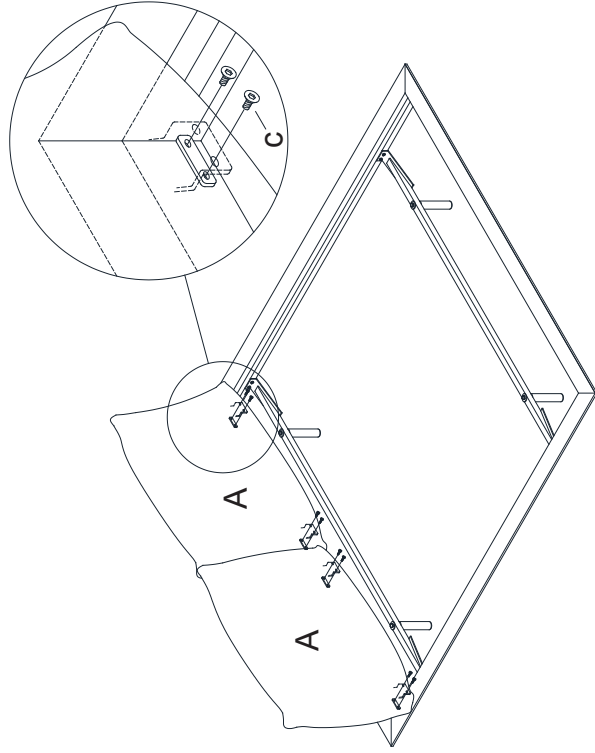

2. Join the upholstered headboards to the side bed surround using the 6Ma screws L:10 mm. by positioning the outermost brackets of the headboards not far from the corner of the aluminum structure.

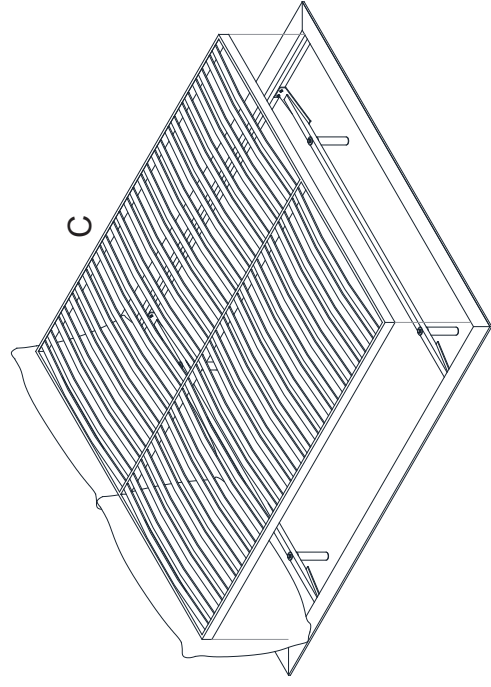

3. Adagiare la rete a doghe all'interno del giroletto.

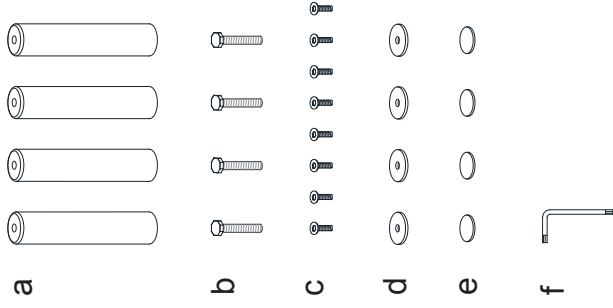
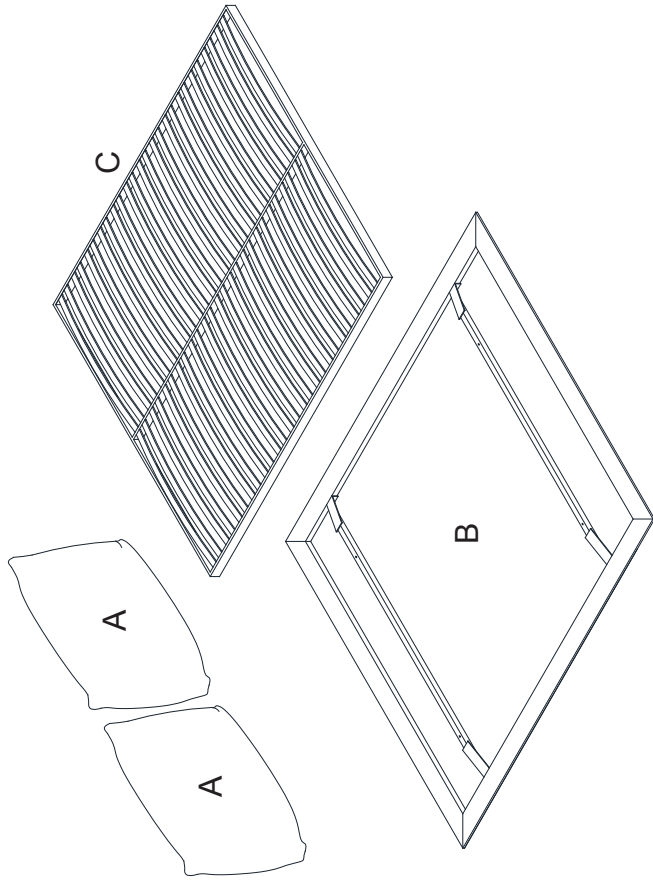

CONTENTS

- A. qty.2 upholstered headboards
 - B. qty.1 aluminium structure
 - C. qty.1 metal orthopaedic slatted base
- a. qty.4 metal feet H.180
 - b. qty.4 screws 10Ma L.50 mm.
 - c. qty.8 screws 6Ma L.10 mm.
 - d. qty.4 washers
 - e. qty.4 rubber caps
 - f. qty.1 setscrews wrenches (L-shaped)